

Technical data CNS 150

PANDA Series



Q.ty	Components	Code	Base	Full optional
1	Solar Panel Panda 2.6 Cu Blue	PANMD3VBN	✓	✓
1	Support structure for flat roof	STCN150SP	✓	✓
1	Enameled solar boiler with cavity, 150 liters	BV0150IIG	✓	✓
1	Solar safety valve, set point 1.5 bar	IDRVSIC15	✓	✓
1	Drain valve with hose connection	IDRVSCGM1	✓	✓
2	Monopropylene glycol - liters	IDRLQGLCL	✓	✓
Connection kit to the solar boiler				
1	Copper pipe (2.5 meters rod)	IDRTR2522	✓	✓
4	Bent connector 90° 3/4 - 22	IDRRACOTC	✓	✓
Solar circuit filling kit				
1	Hose, meters	IDRTP2000	✓	✓
1	Funnel	IDRSRIMB0	✓	✓
Full optional kit				
1	Manual 3 ways valve	IDRV3VM20		✓
1	Mixing valve	IDRVMX020		✓
1	Cross joint	IDRRACCRC		✓
1	Stop valve	IDRVRT020		✓
1	Boiler safety valve, set point 6 bar	IDRVSIC60		✓
1	Ball valve	IDRVINTSF		✓
1	8 liters expansion vessel for solar circuit	IDRVE008L		✓
10	Insulated DN20 piping for hot water distribution, meters	IDRTM2010		✓
4	Straight connector 3/4 - 20 for multilayered piping	IDRRACMSD		✓

PITCHED ROOF

Mod.	Roof	Solar storage tank	Code
CNS150	Pitched	150	CNS150FBB

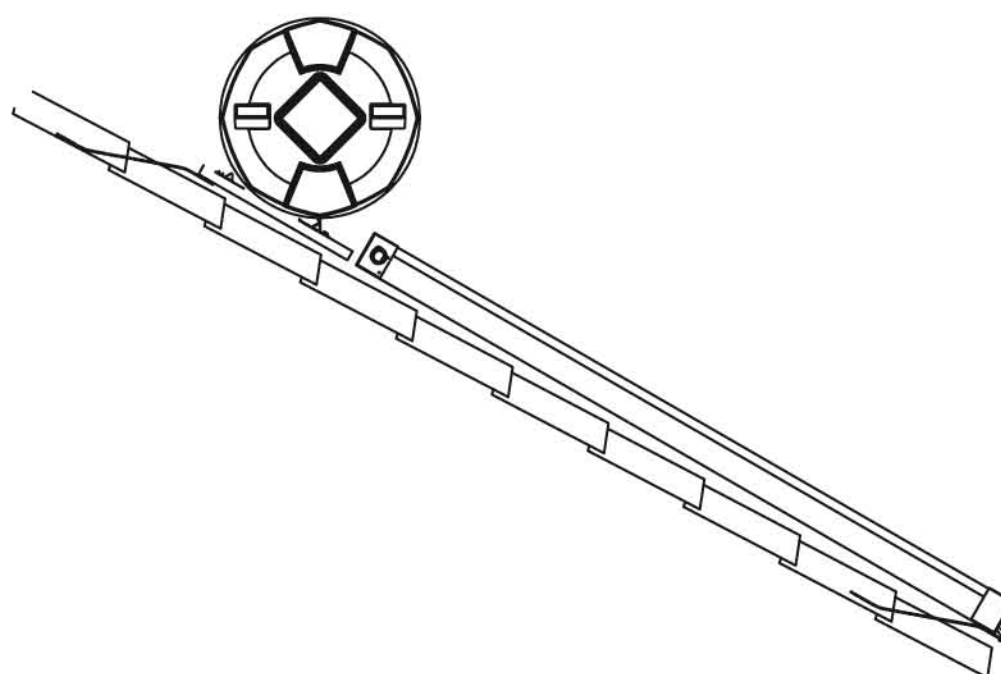
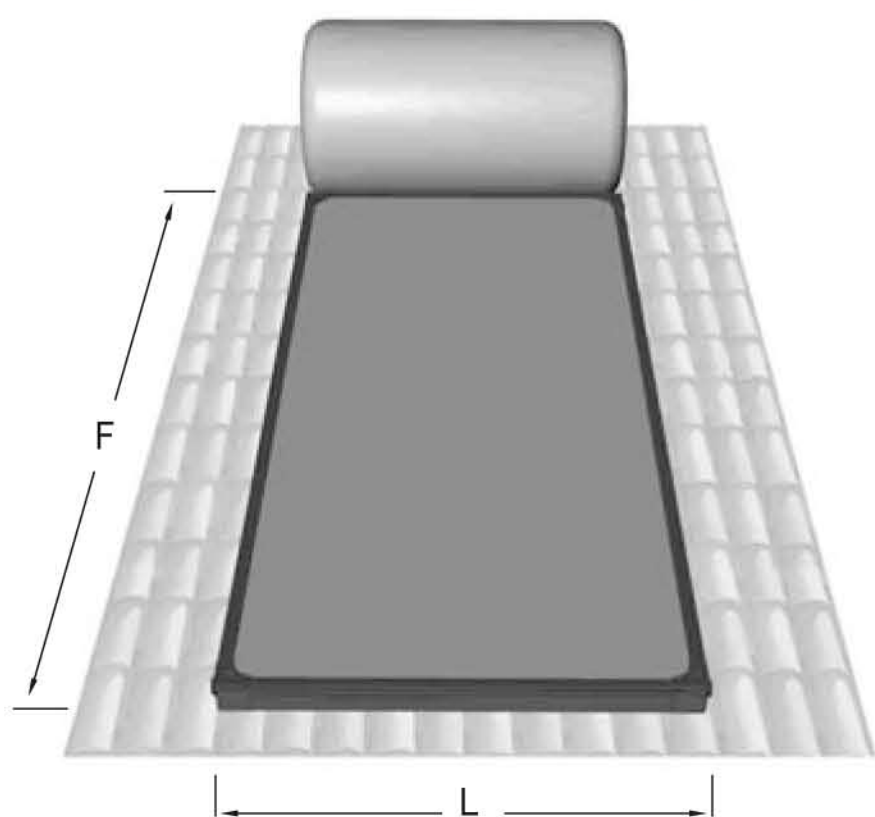

FLAT ROOF

Mod.	Roof	Solar storage tank	Code
CNS150	30°	150	CNS150FBO

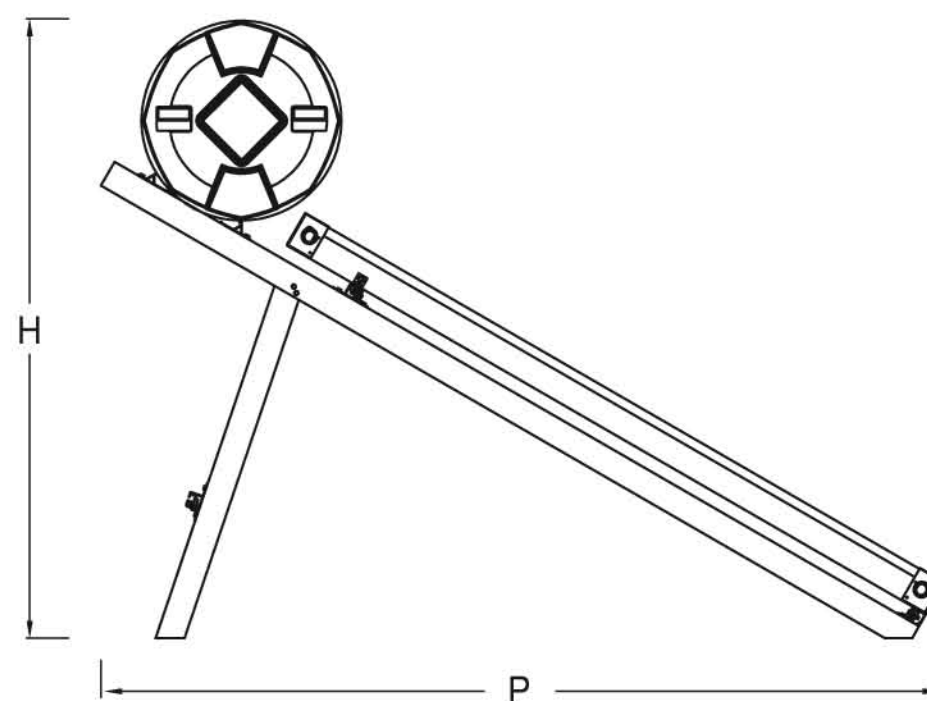
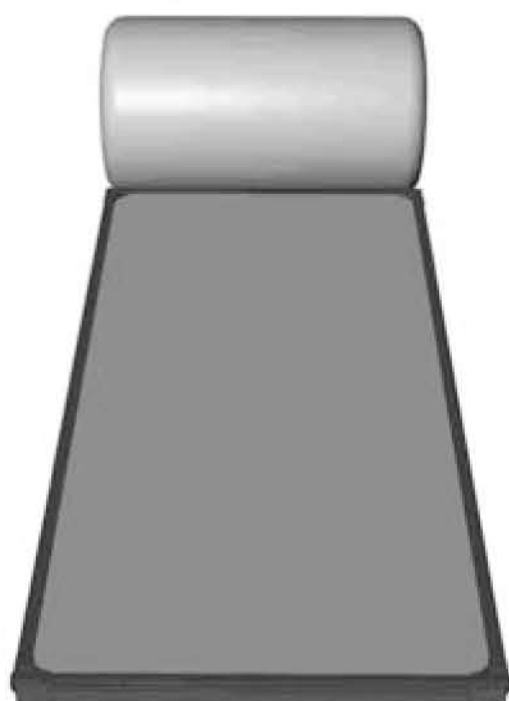

Overall dimensions: **flat roof** LxPxH = 1200x2600x1850 mm empty weight 145 kg
pitched roof LxF = 1200x3000 mm empty weight 130 kg